

# MXT 100 / 100-2

The versatile stirrer up to 50 kg

**EIBENSTOCK**  
P O S I T R O N

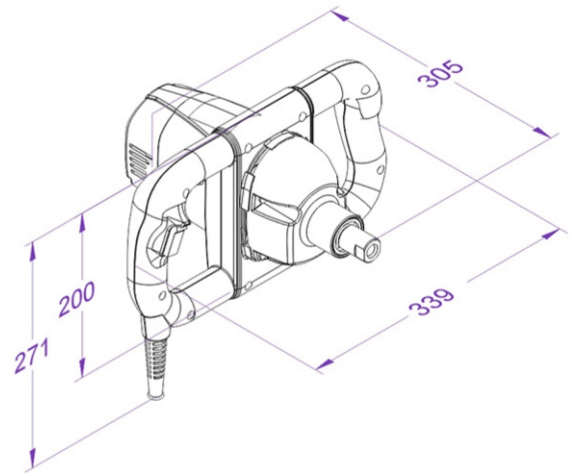

### Use :

- ➔ Mixing of building materials with middle and high viscosity, e.g. filler and leveling compounds, tile cement, ready-mixed mortar and plaster, screed
- ➔ Drywall construction, tiler, plaster, civil engineering, landscaping

### Features :

- ➔ Electronic switch - stepless speed regulation for less splashing
- ➔ M 14 female direct stirrer connection effective power transmission, high concentricity
- ➔ Cap with labyrinth guide protection against dust, dirt, stones, splash water
- ➔ Optional accessory of paddles mixing available on special requirement.



Specifications	MXT 100	MXT 100 - 2
Power input	1100 W	1100 W
Rated voltage	220 - 240 V~	220 - 240 V~
Rated speed	0-580 rpm	0-230 / 0-410 rpm
max. basket diameter	140 mm	140 mm
Spindle connection	M 14 i	M 14 i
Weight (kg)	4	4.5

\* Mixing Paddle not part of Standard accessory